



ISPR Final Lecture

INTELLIGENT SYSTEMS FOR PATTERN RECOGNITION (ISPR)

DAVIDE BACCIU – DIPARTIMENTO DI INFORMATICA - UNIVERSITA' DI PISA

DAVIDE.BACCIU@UNIFI.IT

Lecture Outline

- Course wrap-up
 - A-posteriori view of the course
 - Final take home messages
- Overview of ML research @UNIFI
 - Groups and laboratories
 - Research themes and projects
 - Opportunities
- ISPR Final exam
- Conclusions & Discussion



A Modern View on Pattern Recognition (I)

Dealing with complex data

- Large scale
- Multimodal
- Information in context
- Raw and noisy

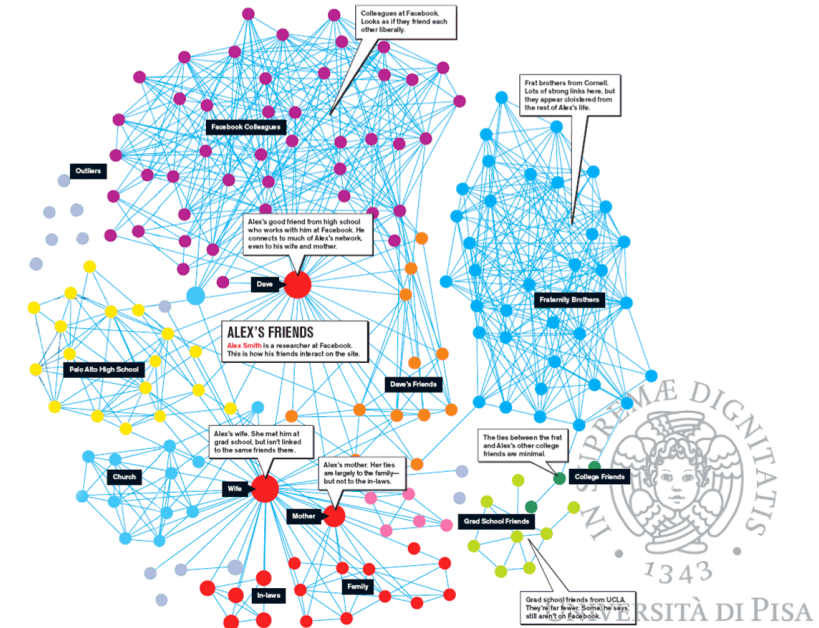
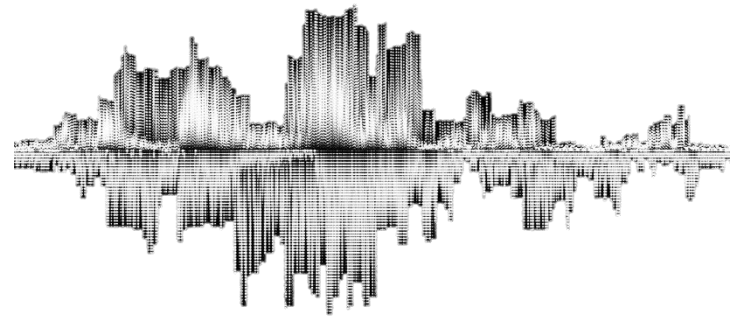
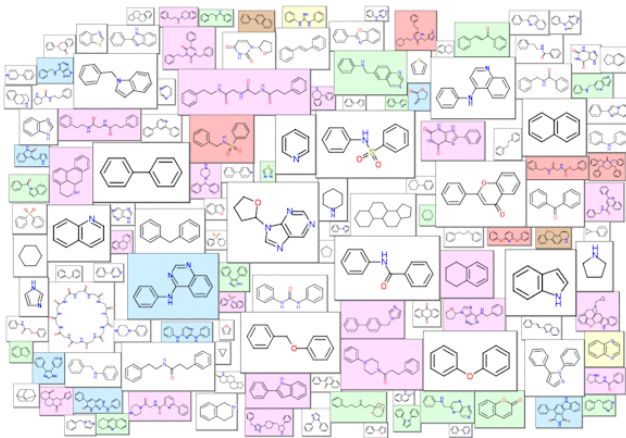

A Modern View on Pattern Recognition (II)

The goals are well past recognition

- Understanding, reasoning and explaining
- Generation
- Creativity
- Search & strategize



The Dowlace

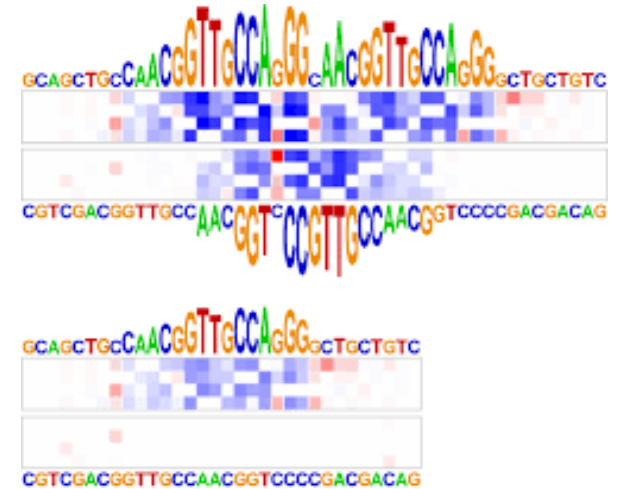

The Course in 1-Slide

- Old-school **pattern recognition**
 - Building blocks: convolution, filters, spectral analysis
- **Probabilistic** models
 - Infer knowledge rather than just predict
 - Introduce prior knowledge
 - How to approximate distributions
 - How to sample distributions
- Deep **Neural Network**
 - Efficient and high predictive performance
 - Non-parametric and non-linear
 - Work on noisy, raw and heterogeneous data
- **Deep Generative** models
 - Learn a generative process
 - How to approximate complex distributions
 - How to sample complex distributions



A Convergence of Neural-Generative Paradigms

- Need the **efficacy and efficiency** of neural models with the **interpretability and generative ability** of probabilistic-based models
- Modular approach
 - E.g. CRF on the top of CNN for semantic segmentation
 - Easily incorporate prior knowledge
- Inbreeding of paradigms
 - CRF as discriminative-generative-energy based models
 - Variational and generative DL
- Mutual support
 - Causal learning

After Completing This Course, Hopefully...

- Know **which learning paradigms and models are best** to start with for addressing a given PR problem
- Know **what challenges** your model will need to solve to realize a PR application
- Know **a bag of tricks** to modify a model to suit your needs
 - Message passing, variational approximations, sampling, latent representations, feature functions, diffusion processes, change of variable and flows,
 - Batch normalization, pretraining, end-to-end differentiability, distribution learning with NN, enhancing memory, attention, adversarial learning, invertible neural layers, on the importance of gaussian noise
 - Randomized NNs, alternatives to backprop, learning with graphs, causal Vs observational models



Machine Learning is the New Algorithmics

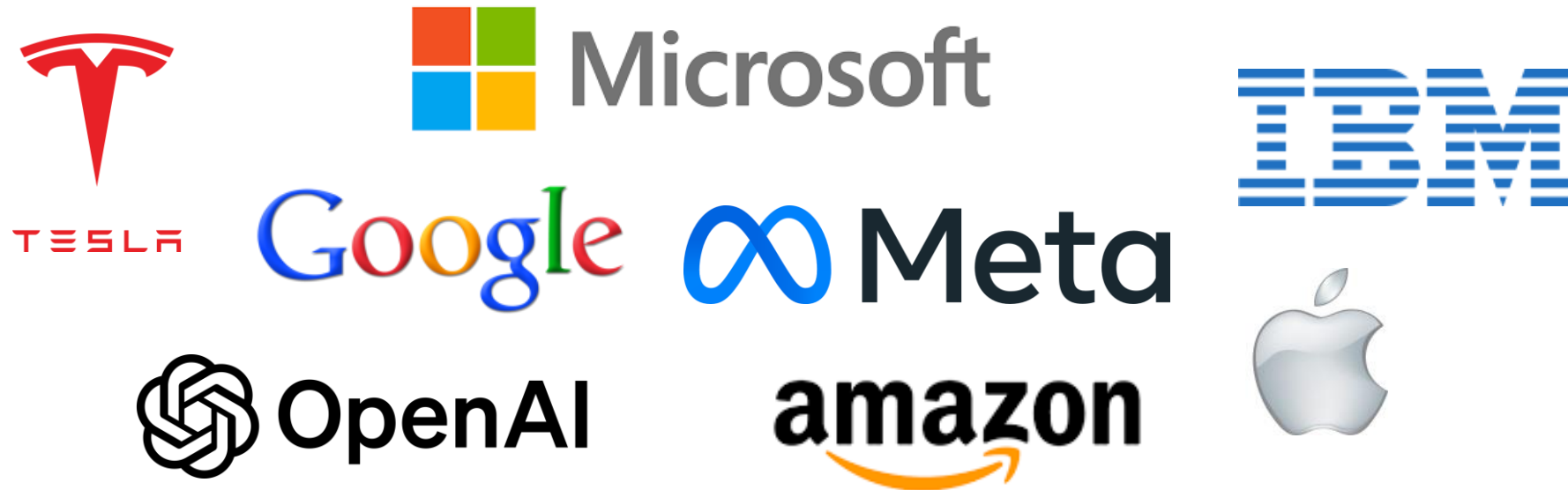

Can you derive EM for GMM?

When do you need to check you gradient?

Implement a Gaussian/edge filter

Research Groups



Computational Intelligence & Machine Learning Group (CIML)

- <https://ciml.di.unipi.it/>
- Coordinated by Alessio Micheli
- Focus on pure Machine Learning



Pervasive Artificial Intelligence Laboratory (PAI Lab)

- pai.di.unipi.it
- A joint initiative by Dipartimento di Informatica @ UNIFI and Istituto Scienza e Tecnologia dell'Informazione @ CNR
- Coordinators – Davide Bacciu and Patrizio Dazzi
- >15M Euro EU grants
- Focus on AI & Pervasive Computing



Research Overview

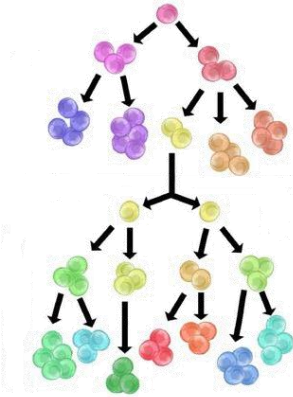
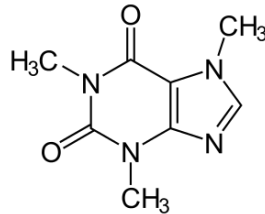
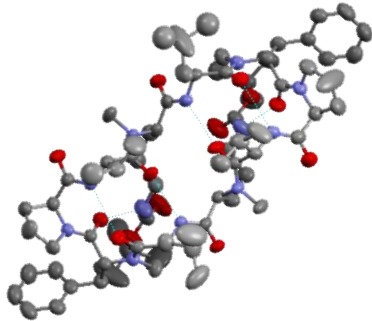

- Learning for graphs & structured data
- Deep learning and neural networks, generative models, RL, causality
- Pervasive AI (distributed, embedded, morphological/neuromorphic, continual)

EMERGE



UNIVERSITY OF CAMBRIDGE



Funded by Italian, European and industrial projects

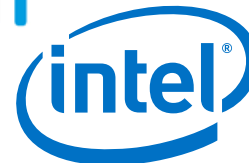

UNIVERSITÀ DI PISA

Topics of current research (I)

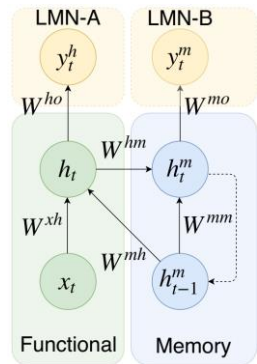

Recurrent neural networks

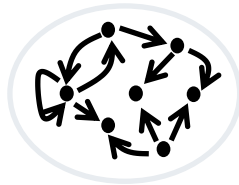

- (Deep) Reservoir computing and randomized networks
- New paradigms of dynamic memory
- (Neuro)morphic computing and dynamical systems

Learning with structured data

- Deep learning for graphs
- Graph generation
- Algorithmic reasoning
- Efficient neural diffusion

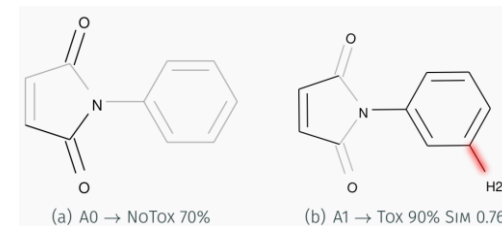
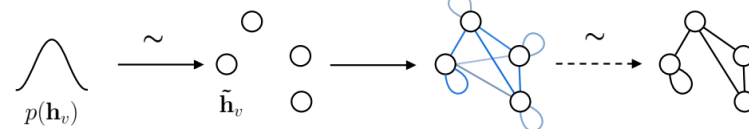
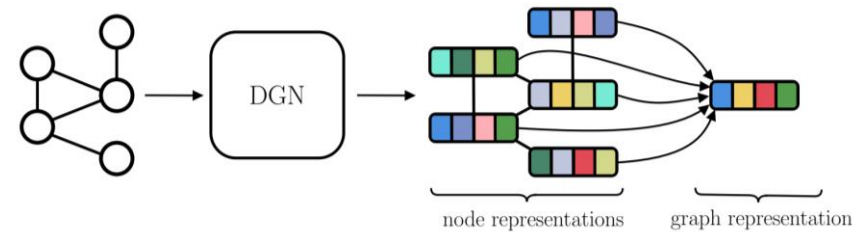

UNIVERSITÀ DI PISA

Topics of current research (II)

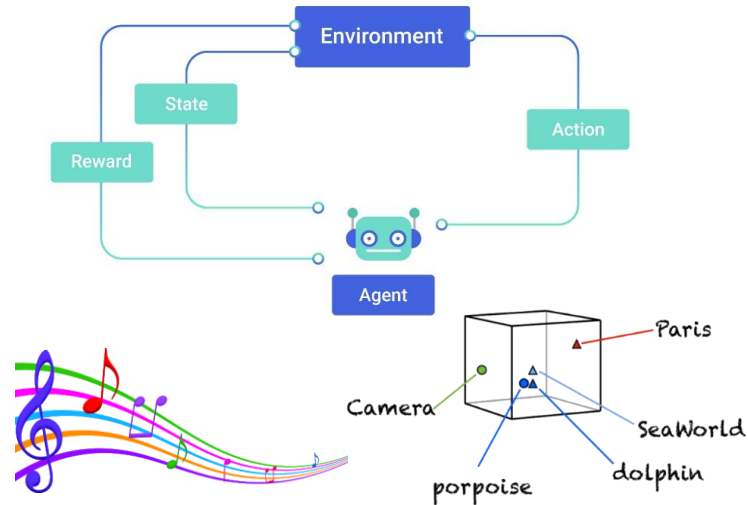

Learning Fundamentals

- Continual learning
- Federated learning
- (chemical, physical, *) Informed NNs
- Learning-symbolic integration & reasoning
- Reinforcement learning and learning under weak/self/noisy supervision
- Theoretical properties of deep NNs

FEDRAY



Pervasive AI

- Distributed learning
- In-silico embedded intelligence
- AI on GPU/FPGA/Cluster computing
- ML as a service & ML-based application development
- Trustworthy & human-centered learning

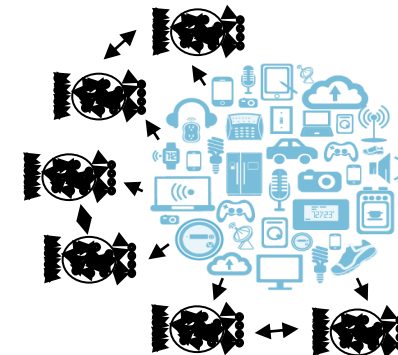

Topics of current research (III)



Causal learning & Trustworthy AI

- Robust, safe and secure deep learning
- Learning causal models
- Continual learning for robustness

Applications of learning systems

- Recommendation systems
- Machine vision & multimedia
- Bioinformatics
- Chemistry
- Robotics
- Autonomous Vehicles
- Physio-signal processing

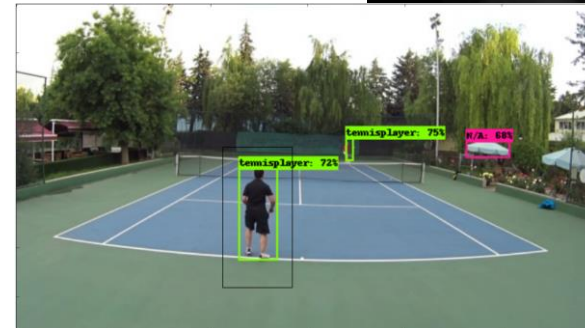
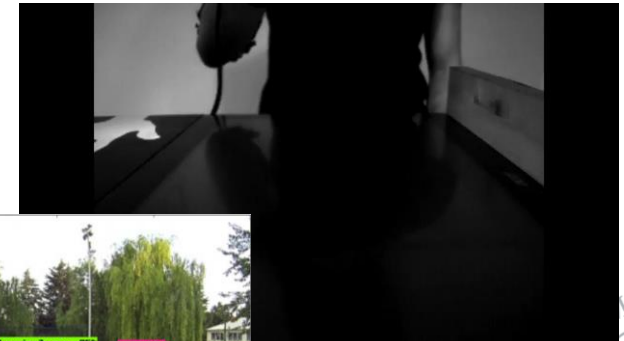
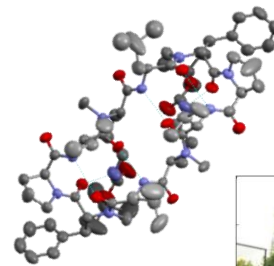

And many other things...

- Generative and unsupervised deep learning
- Computational creativity: music generation and style transfer; visual arts
- Medical imaging
- Robotics & embodied intelligence
- ...

Contact if interested in M.Sc. and Ph.D. projects



UNIVERSITÀ DI PISA

Active Projects & Initiatives

- EU HorizonEU CoEvolution: Trustworthy Framework for Connected ML and (2024-2027)
- EU EIC Pathfinder EMERGE: Emergent awareness from minimal collectives (2022-2026)
- EU H2020 TEACHING: A computing Toolkit for building Efficient Autonomous applications leveraging Humanistic Intelligence (2020-2023)
- FAIR AI research network: Continual learning transversal project & deep learning for graphs (2022-2025)
- EU H2020 TAILOR: Trustworthy AI Integrating Learning, Optimization and Reasoning (2020-2023)
- MIT-UNIFI international project on deep learning for optimization problems
- H&M Industrial collaboration on Deep Learning for Graphs
- Cornelis Network industrial collaboration on Pervasive AI
- Startups: Aptus AI, ContinualIST, QuantaBrain



TEACHING - Motivation & Vision



A **human-centric** perspective on **autonomous** CPSoS applications



TEACHING - Motivation & Vision

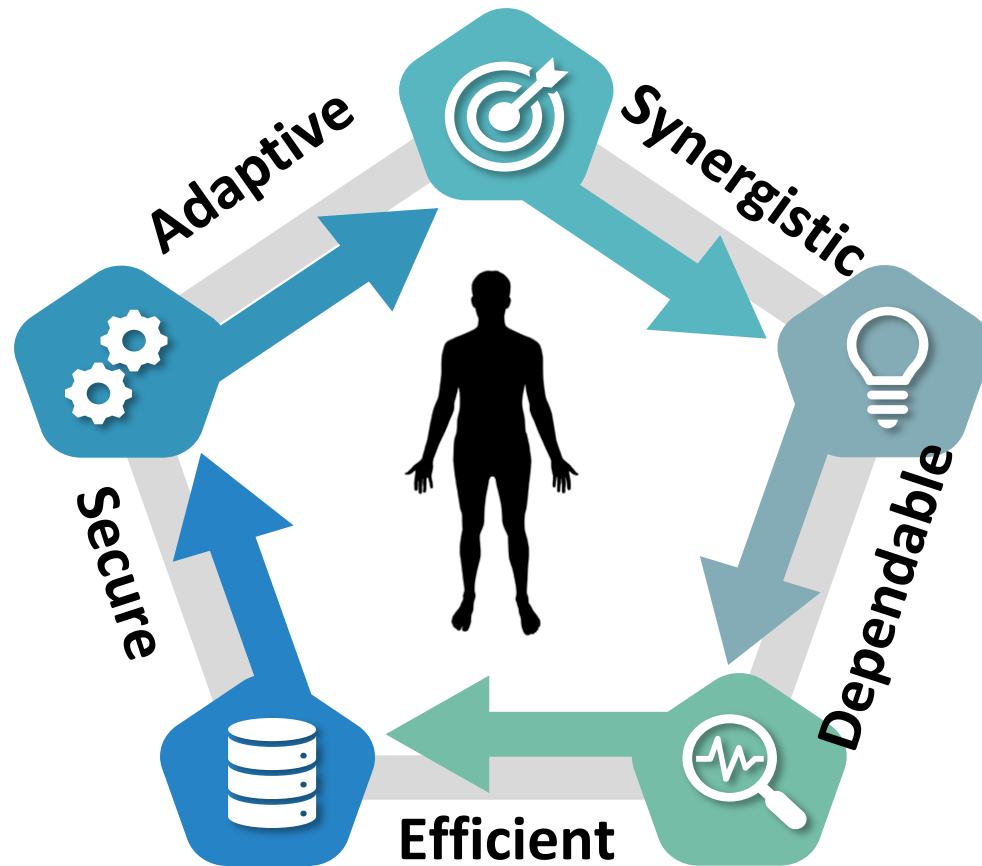

A human-centric perspective on **autonomous** CPSoS applications

Paradigmatic shift needing support at **computing and system** level

TEACHING – Autonomous Driving App

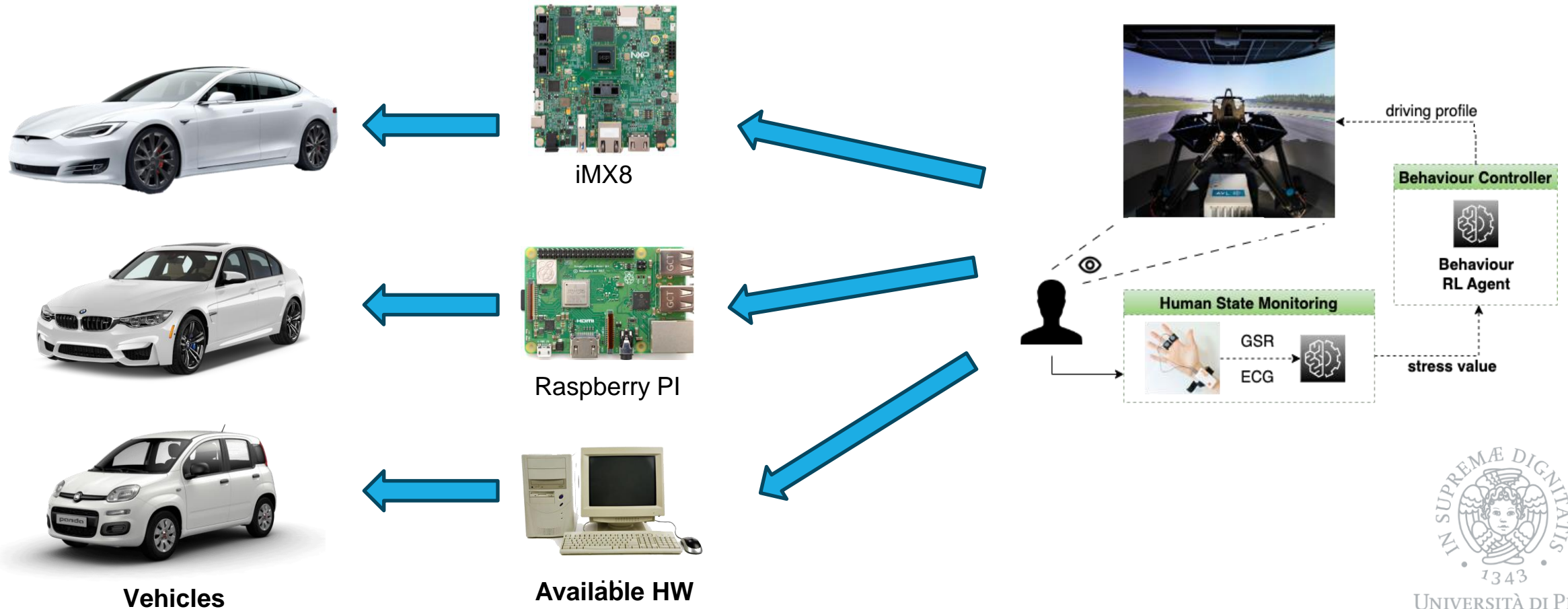

TEACHING Driving Platform @ PAILAB



Human
state
estimation



TEACHING – AI as a Service for Safe Adaptive Distributed Applications

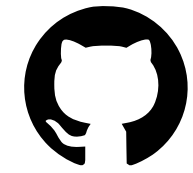
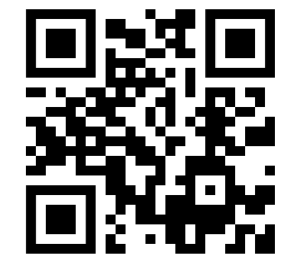
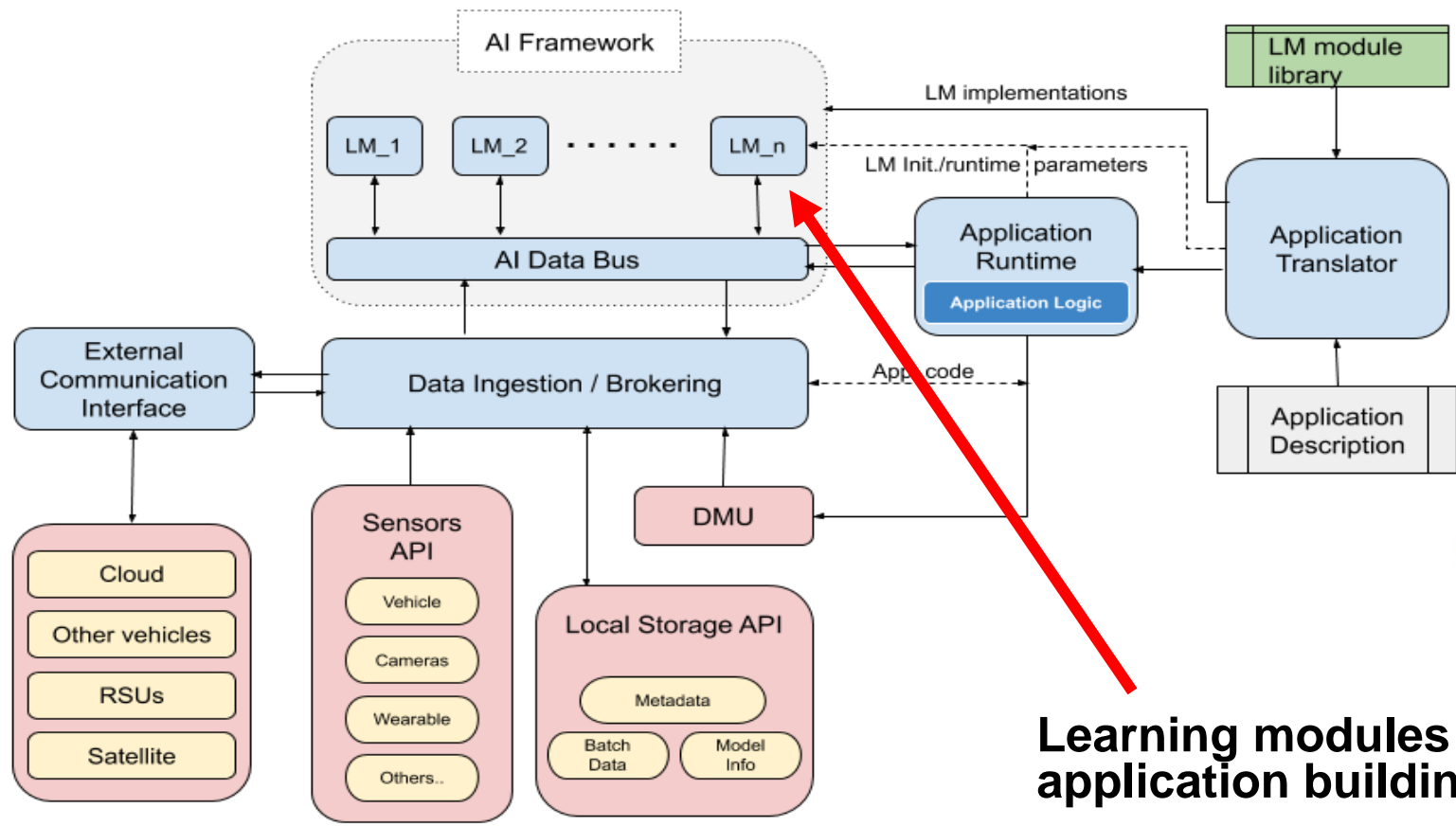

<https://github.com/EU-TEACHING>

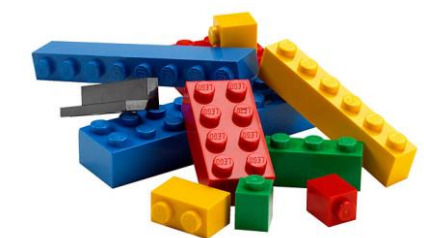

Learning modules as application building blocks



H2020 TAILOR (2020-2024)



Trustworthy AI - Integrating Learning, Optimisation and Reasoning

ICT-48 Network of research excellence centres on foundations of Trustworthy AI

- 55 partners; >75 affiliated labs
- Research program to address grand challenges
- Connectivity fund for active dissemination to the larger AI community
- Network collaboration activities (exchanges, events, joint supervisions)

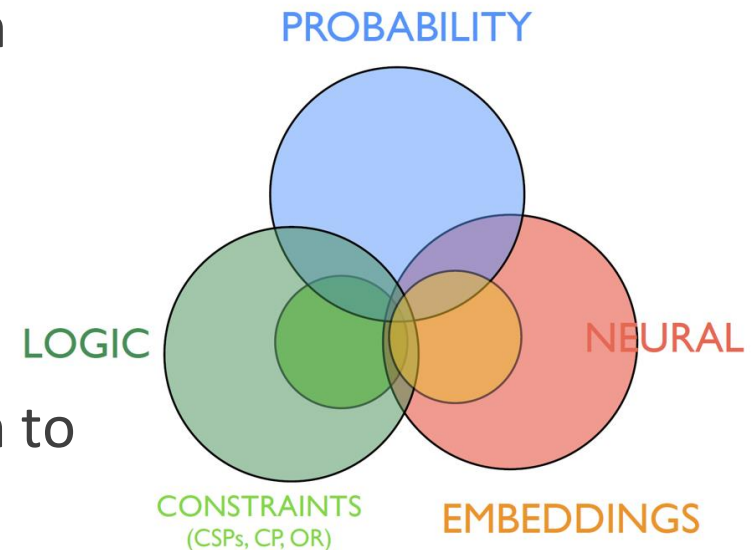

tailor-network.eu



UNIVERSITÀ DI PISA

EMERGE – Awareness of Minimal Collectives



Emergent awareness
from minimal collectives

Funded by the European Union
under Grant Agreement 101070918



Funded by
the European Union

European
Innovation
Council



EMERGE – Aware Minimal Collectives

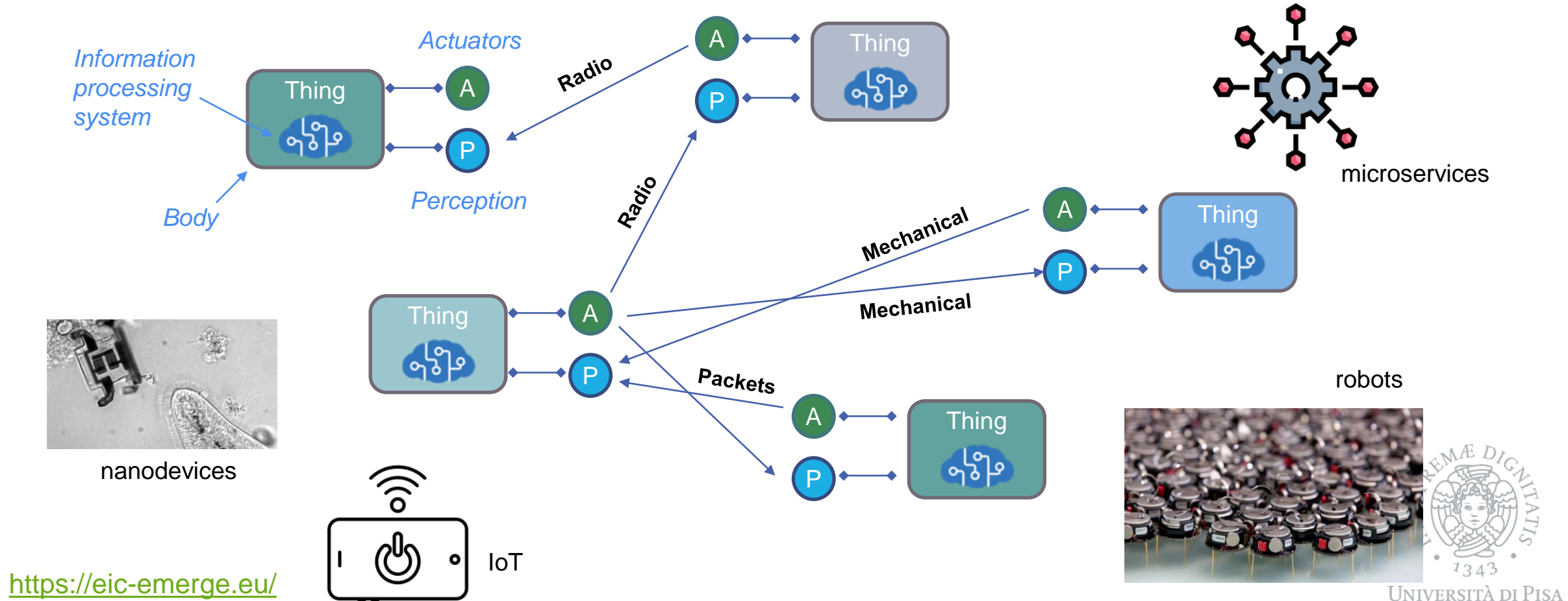

Novel Neural Computing Framework

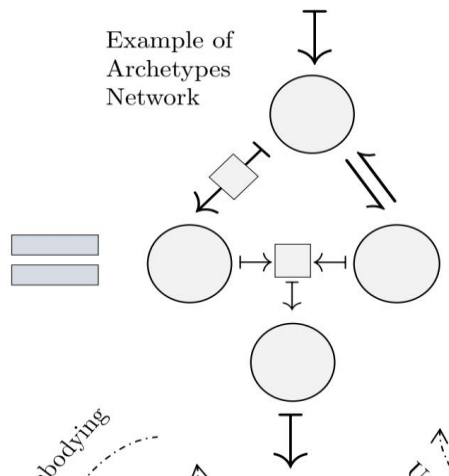
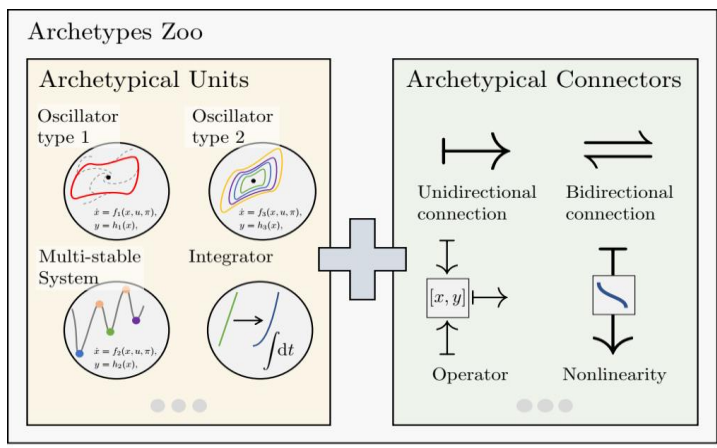

Uncovering
Embodying

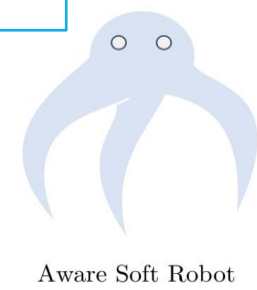

Latent compressed representations for control

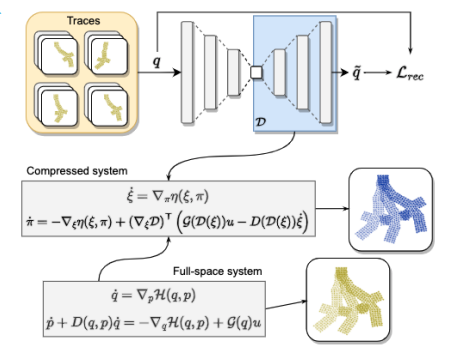

Learning physically-consistent dynamics of manipulators

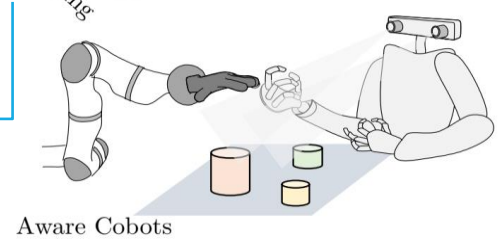
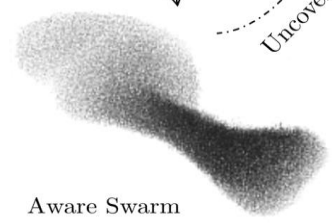

Learning soft-object dynamics from perceptions

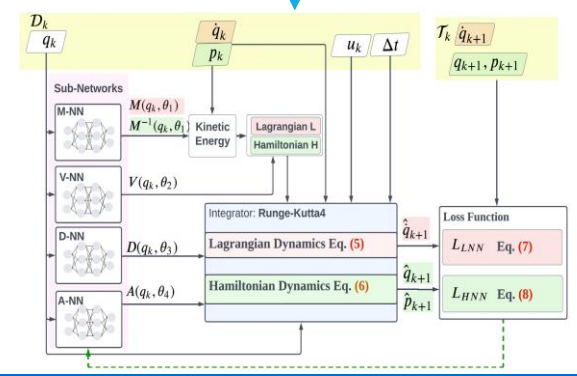
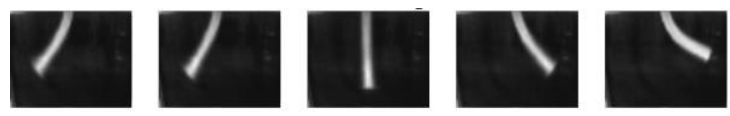

Neural Computing on Dynamical Systems

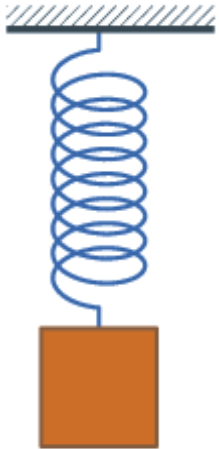

- Neural processing on **multi-stable harmonic oscillators**
- Family of **efficient and expressive neural networks** for dynamical data
- Physically implementable Neural Networks
- Neural Networks of Neural Networks

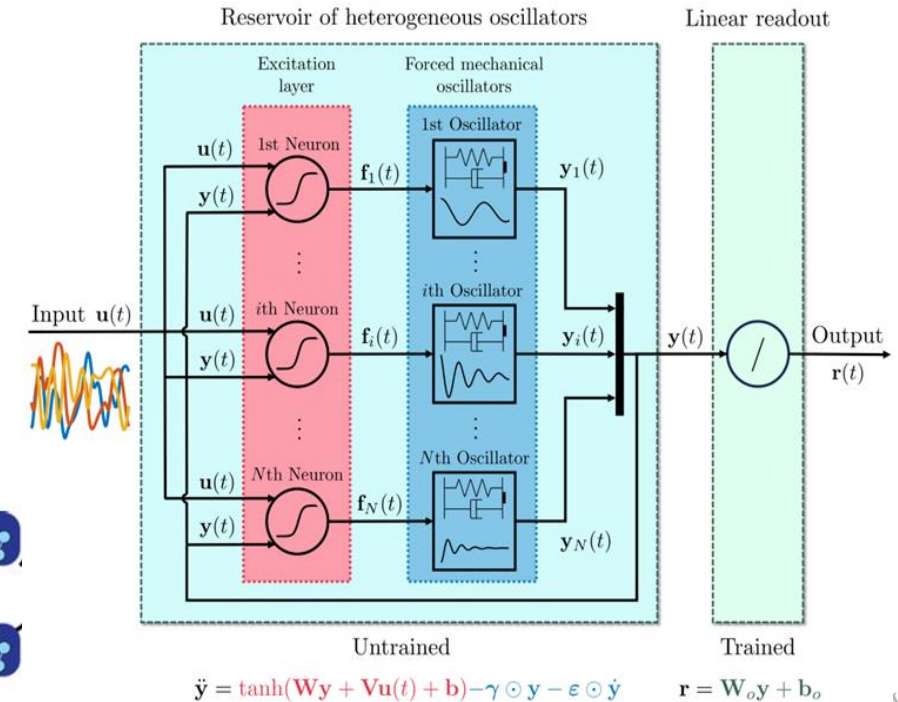
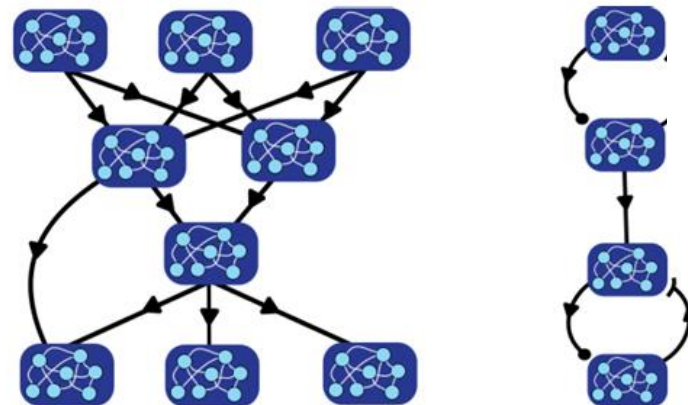

EMERGE – Use Cases

- Modular **soft robots** - Dynamic addition of components
- Robotic **swarms** - Large scale minimal collective
- **Cobots** - Marketable use case where interoperability is a need



The EMERGE consortium:



Funded by
the European Union

Funded by the European Union under
Grant Agreement 101070918

CoEvolution (Kickoff Nov 2024)

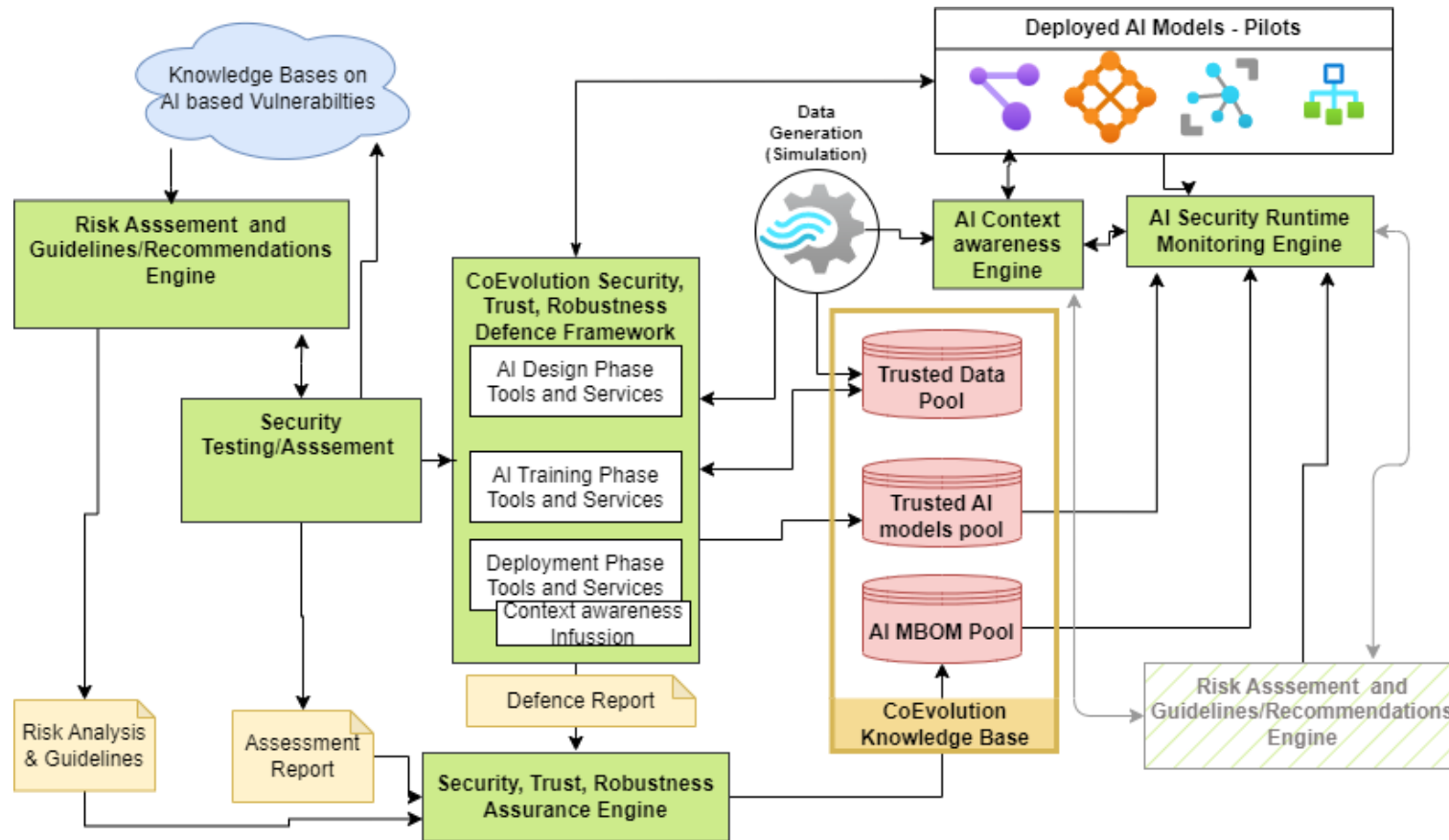

Post-deployment security and robustness through incremental and continual learning



Midterm 4 – RL & Advanced Models

- Format
 - Read 1 paper on a course topic
 - From a list of referenced papers
 - Prepare an 8 slides presentation with the following (rough) content
 - Introduction to the problem
 - Model description
 - Key catch of the model, represented by a commented equation
 - Key (empirical) result
 - Comment on novelties, strong points and weaknesses
- Deliver the presentation by the **19-06-2024**
- Unless you are going for first appello: **then deadline 28-05-2024**



Final Projects (Alternative to MIDTERMS)

- **Survey**

- Read at least 3/4 relevant papers on a topic
- Prepare 10 pages report + 1 presentation (for oral day): not a simple summary but find connections between the works and highlight open problems

- **Software**

- Develop a software implementing a non-trivial learning model, and/or an application relevant for the course, and/or documenting a solution for an ML challenge available on the web
- Prepare a presentation (for oral day) describing the software/challenge and its validation/results



Final Projects – What to Deliver?

- Two things need to be delivered (by the [Appello deadline](#))
 - A written report or the code for the project
 - A presentation on the project (for either type)
- Presentation will last [15 minutes](#) and will be given on the [oral day](#)
- Presentation tips
 - (Survey) Summarize the ideas, models and results
 - (Software) Describe the implemented model, the library and the experimental validation
 - My suggestion is to keep the number of slides around 15 (tops)



Final Exam Timeline

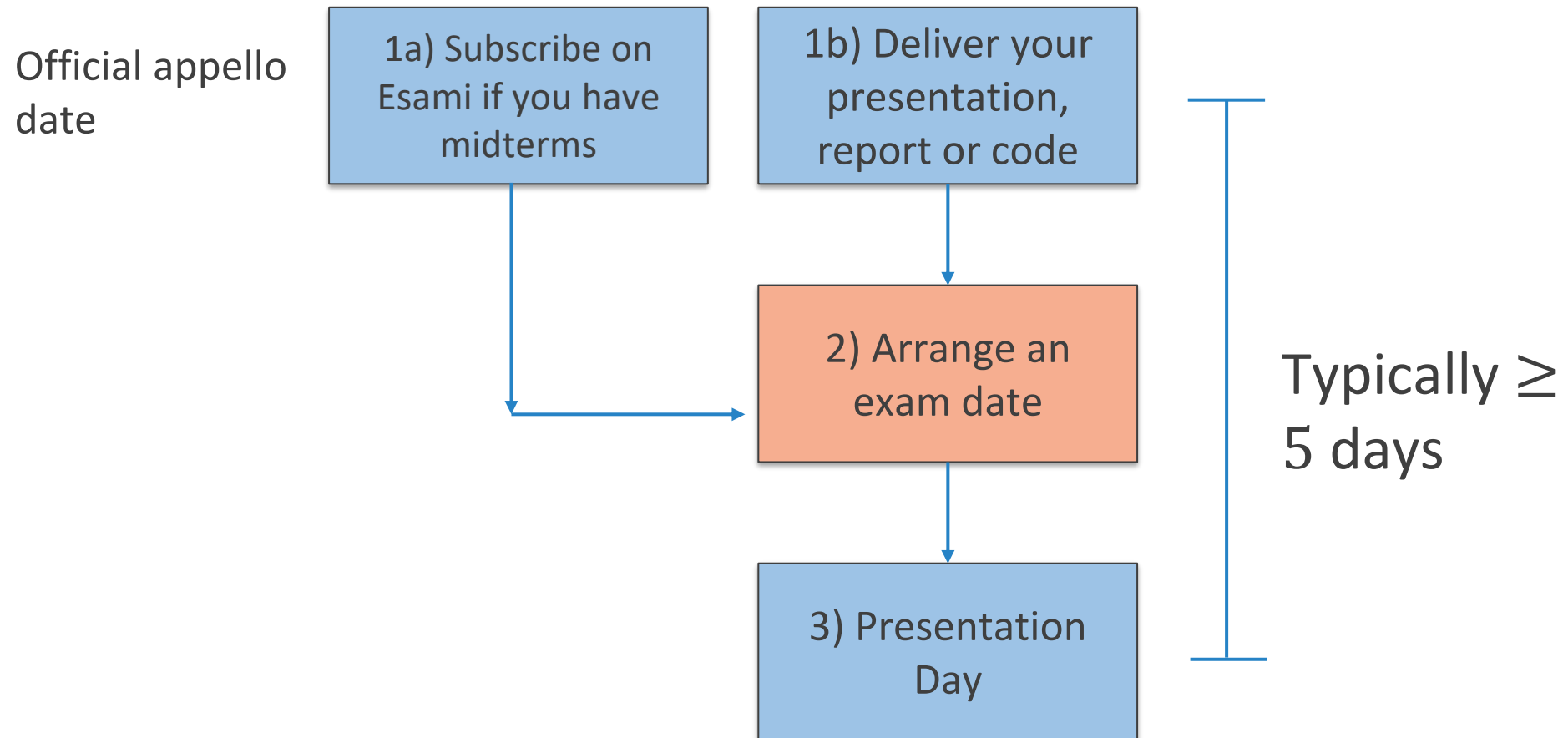

Presentation, Report & Code Delivery

Fixed and strict deadlines for handling the presentation, report and/or code to me

1. 28/05/2024 h. 09.00
2. 19/06/2024 h. 09.00
3. 15/07/2024 h. 09.00

Delivery through the ISPR moodle

- Submit presentation, report, code in a single archive file (no data!!!!)



On the Oral-Presentation Day

- Oral exams will be held in-person
 - Check for room information and dates on the Moodle
 - All students are welcome to attend
- Non-midterm students will first deliver their presentation
- All students will be subject to an oral exam on models, algorithms and applications discussed during the course lectures
 - A. Ceni, A. Cossu, W. Meira and R. Massidda lectures are not part of the exam programme



FAQs

- What is the **language** for the report and the presentation?
 - Both need to be written in English, but the presentation can be given in either Italian or English
 - The oral exam can be in either Italian or English (your choice)
- How long do **midterms last**?
 - Until September exams (included)
 - Yes, I will keep them even if you give the exam and fail it (not if you fail it because of plagiarism though)
- Other questions?



Concluding

- I hope you have enjoyed the course
- I will be out of my office:
 - 10 June-12 June
 - 26 Jun-11 Jul
 - 12-30 August

Enjoy the rest of you AI curriculum

